

eagle schematics for the first prototype of the umodular synth

created by: Arthur from sinneb.net

open source, open hardware

check build notes, todo's and wishes on sinneb.net

24th of February 2016.

All TL274 opamps -> TL072

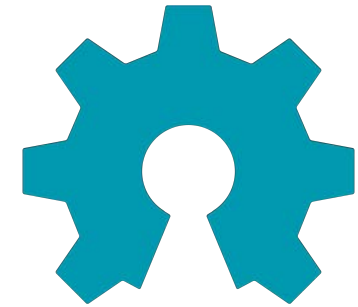

**open source
hardware**

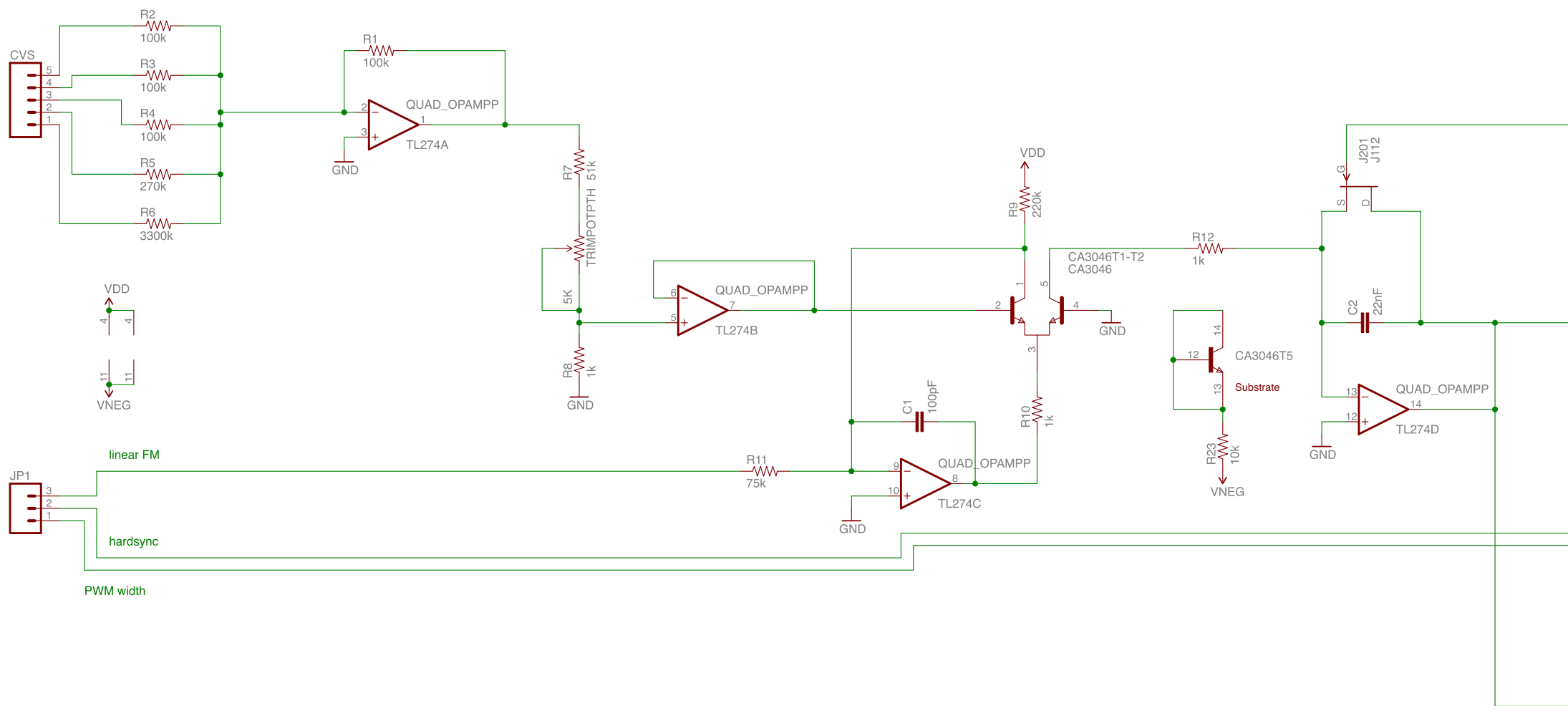

vco 1

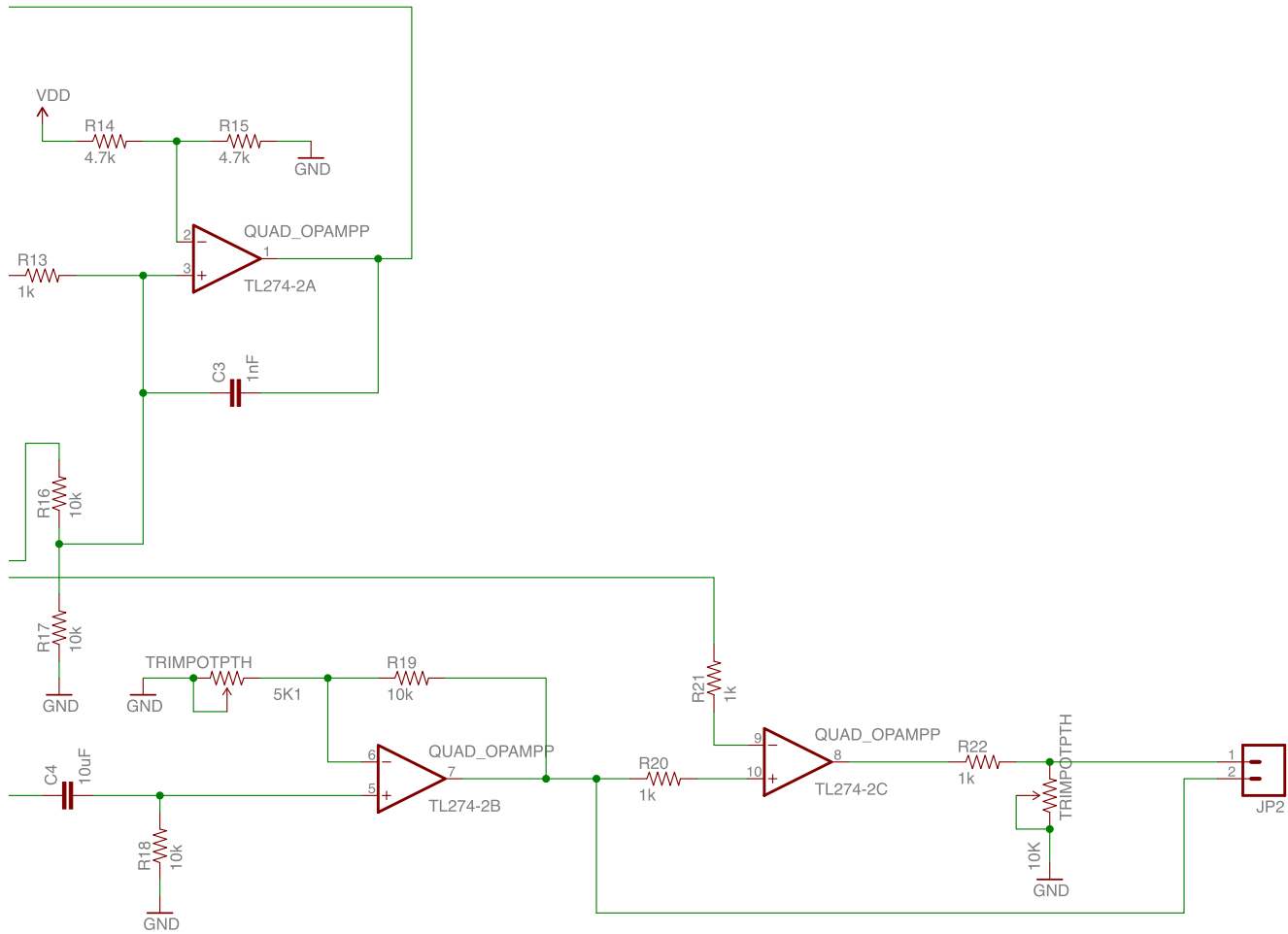

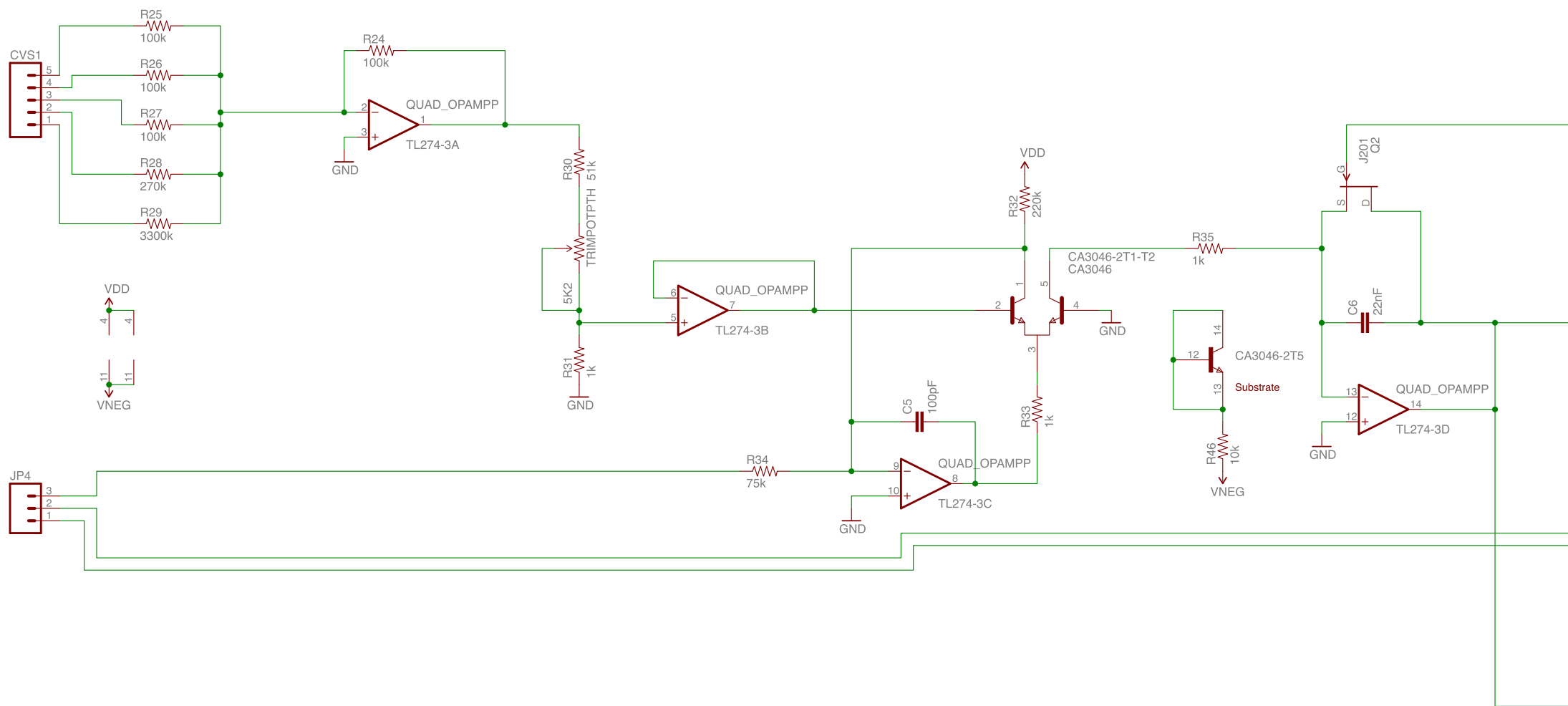

vco 2

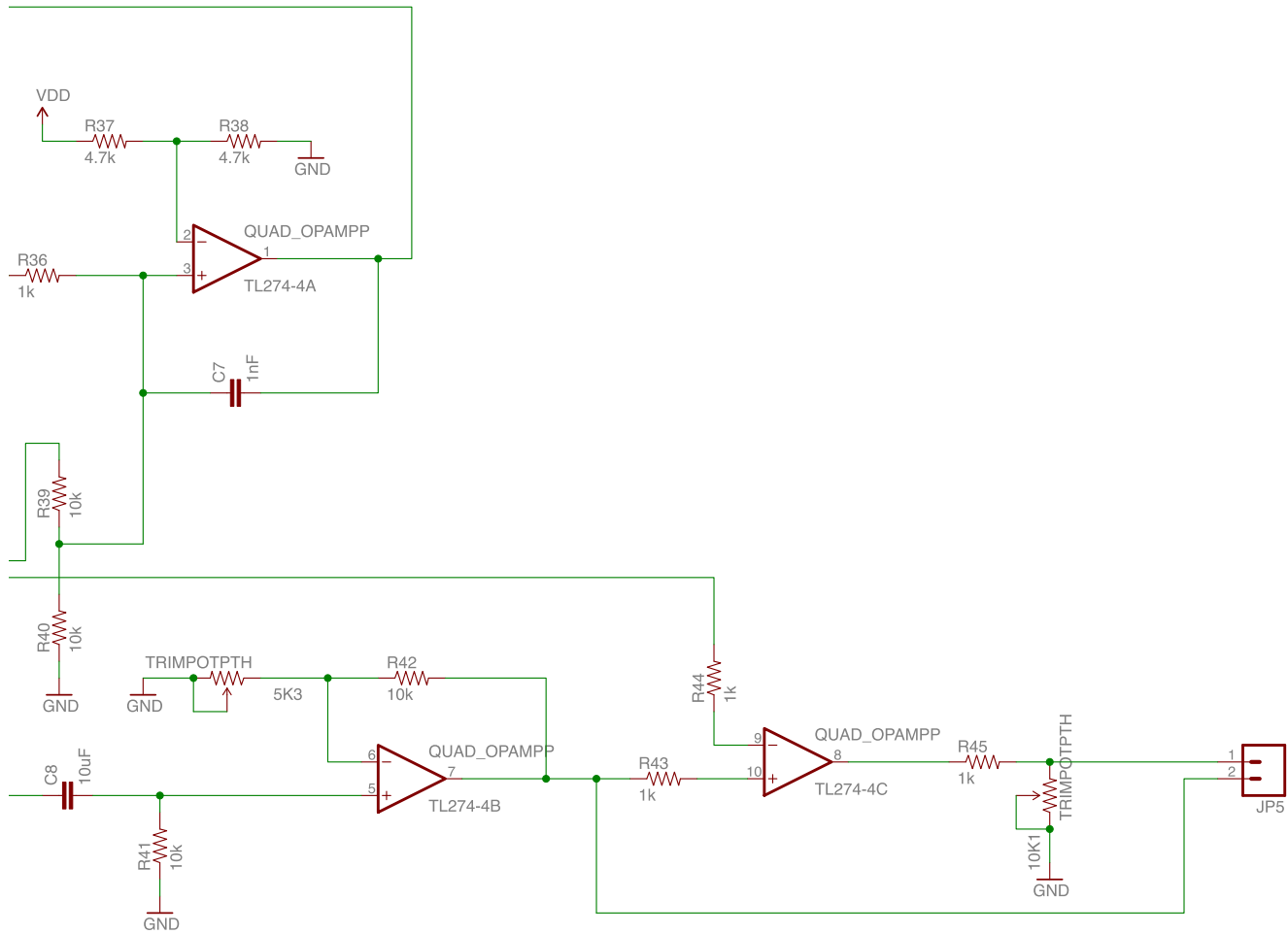

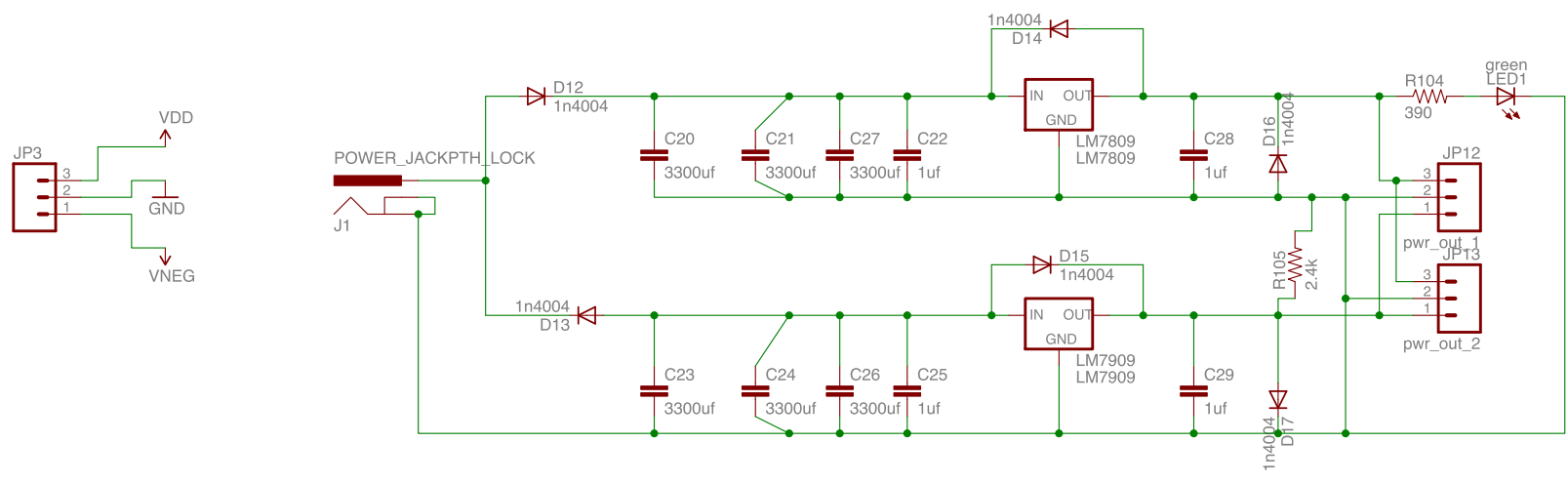

power section, input 9v AC

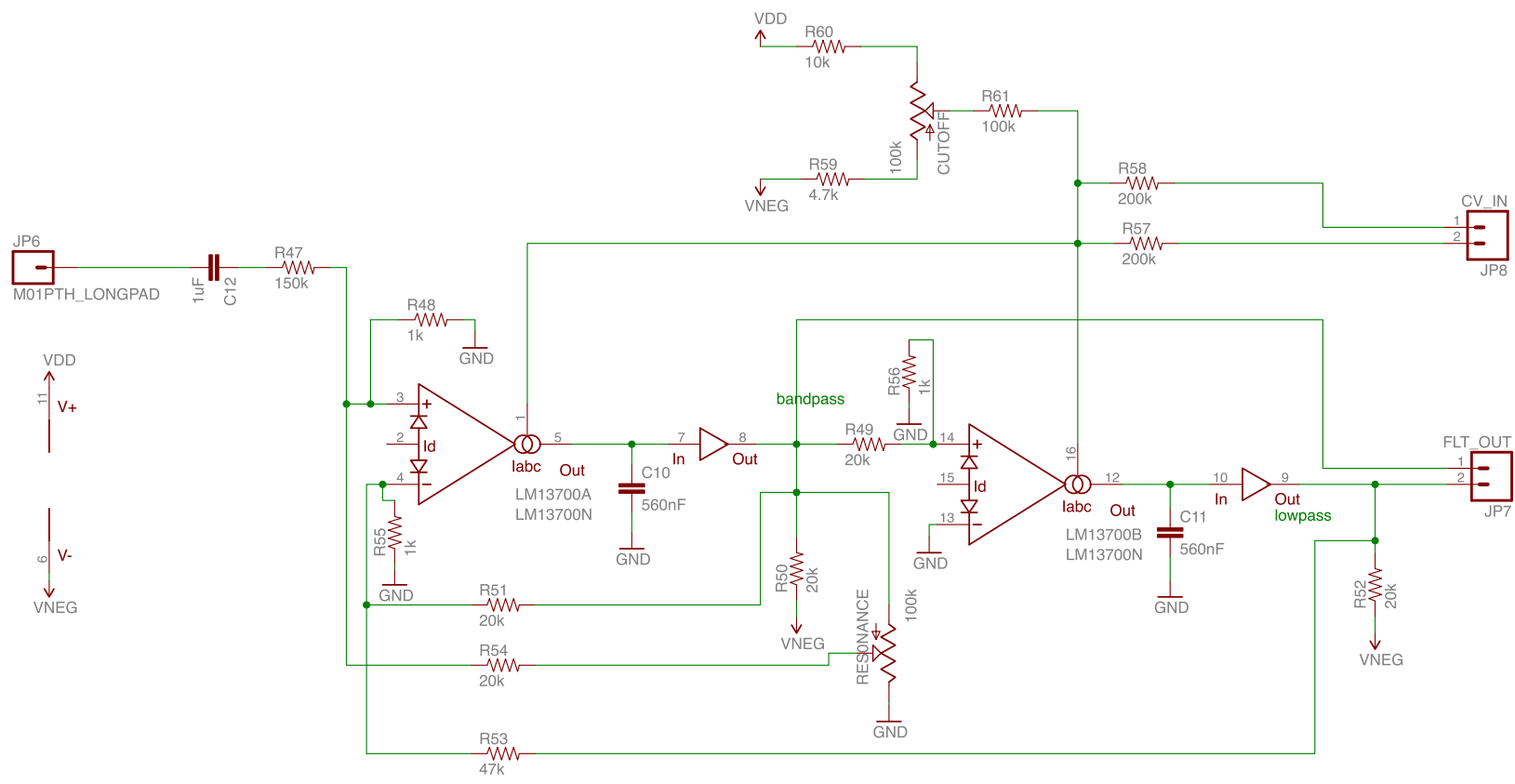

VCF, designed by Ray Wilson, non-commercial use

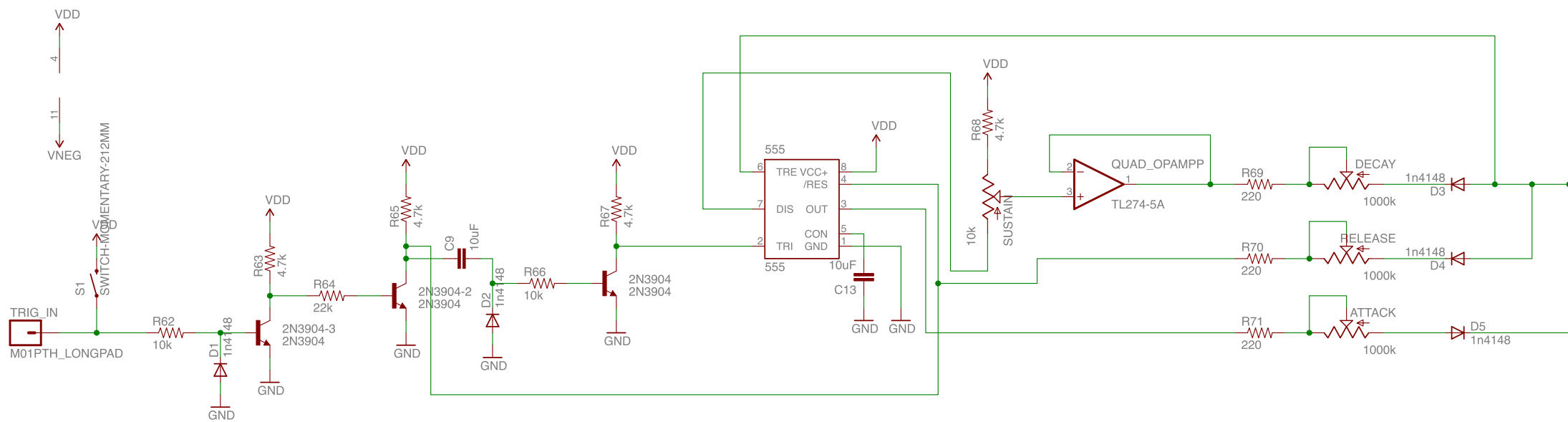

ADSR1, designed by Rene Schmitz, used with permission

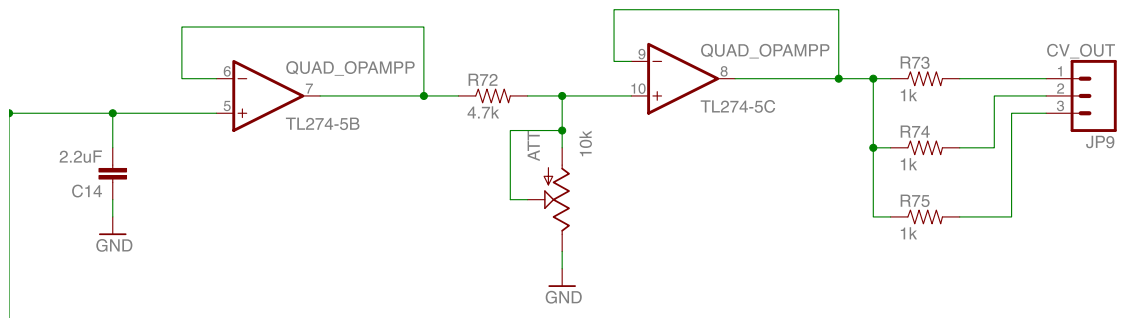

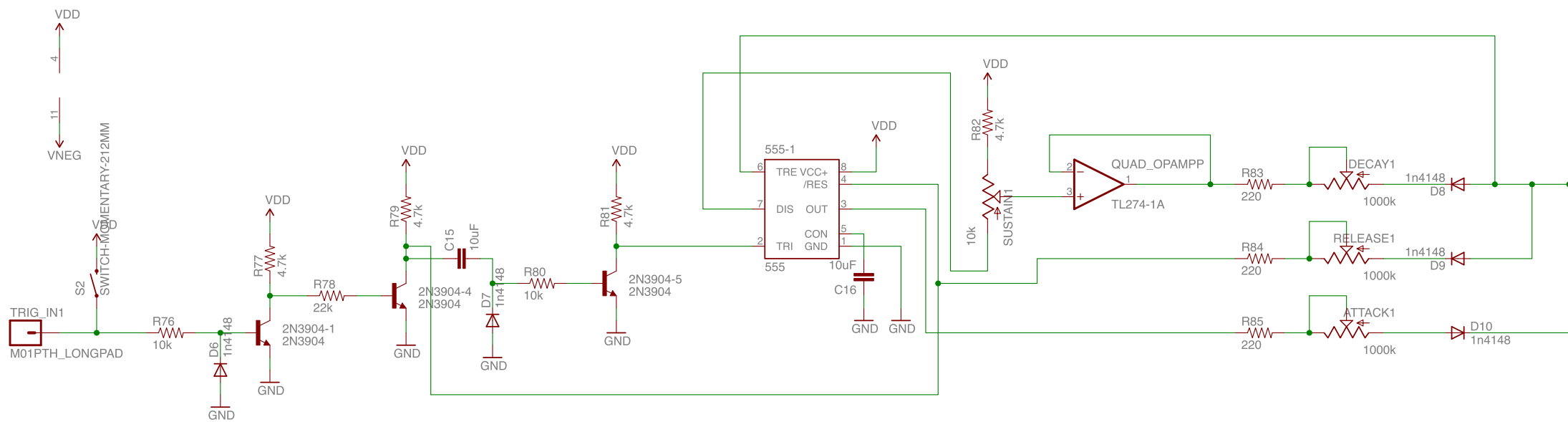

ADSR2, designed by Rene Schmitz, used with permission

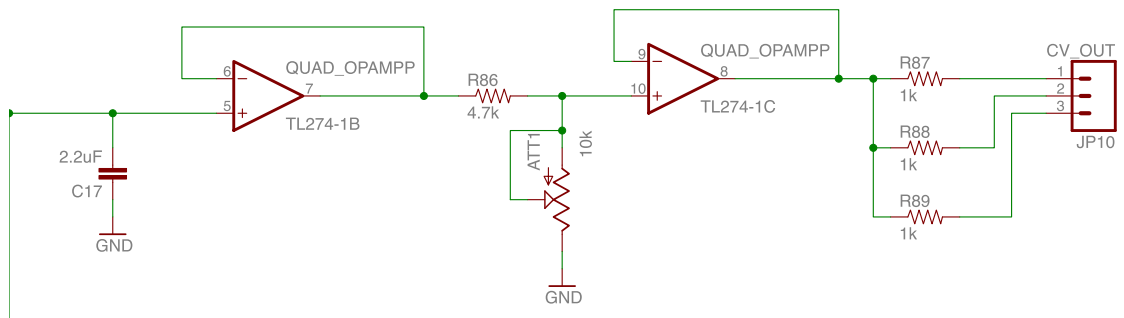

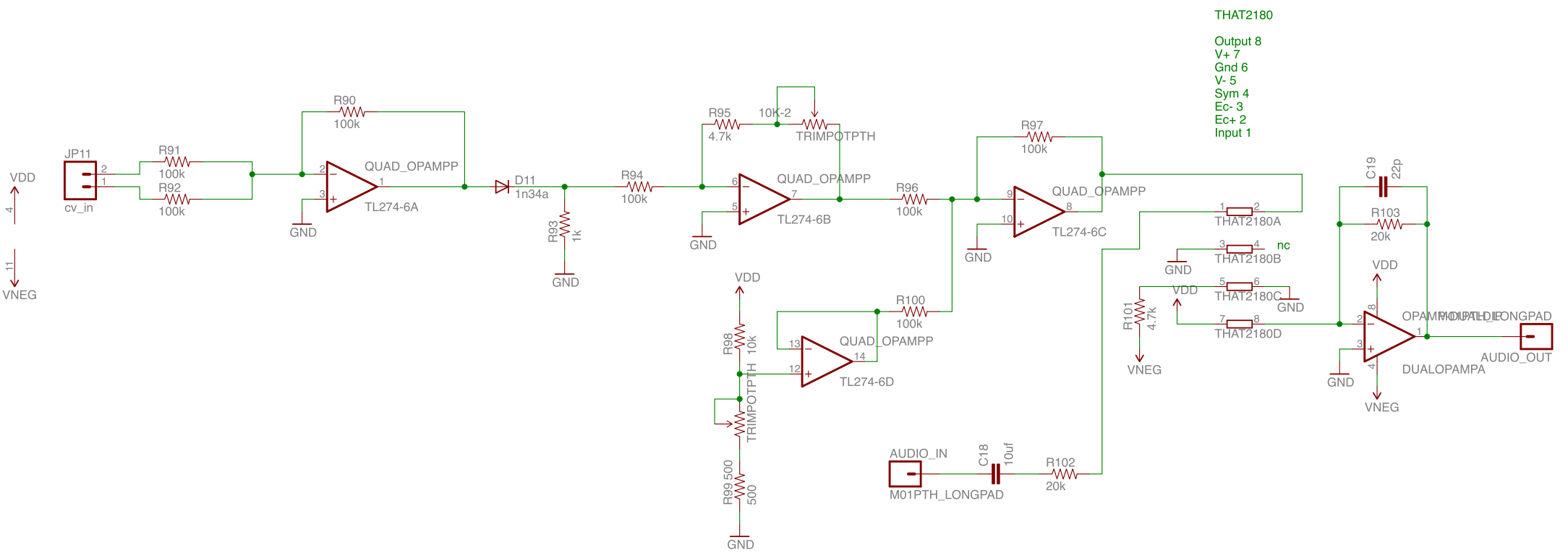

THAT2180
 Output 8
 V+ 7
 Gnd 6
 V- 5
 Sym 4
 Ec- 3
 Ec+ 2
 Input 1

VDD
 4
 11
 VNEG

VCA

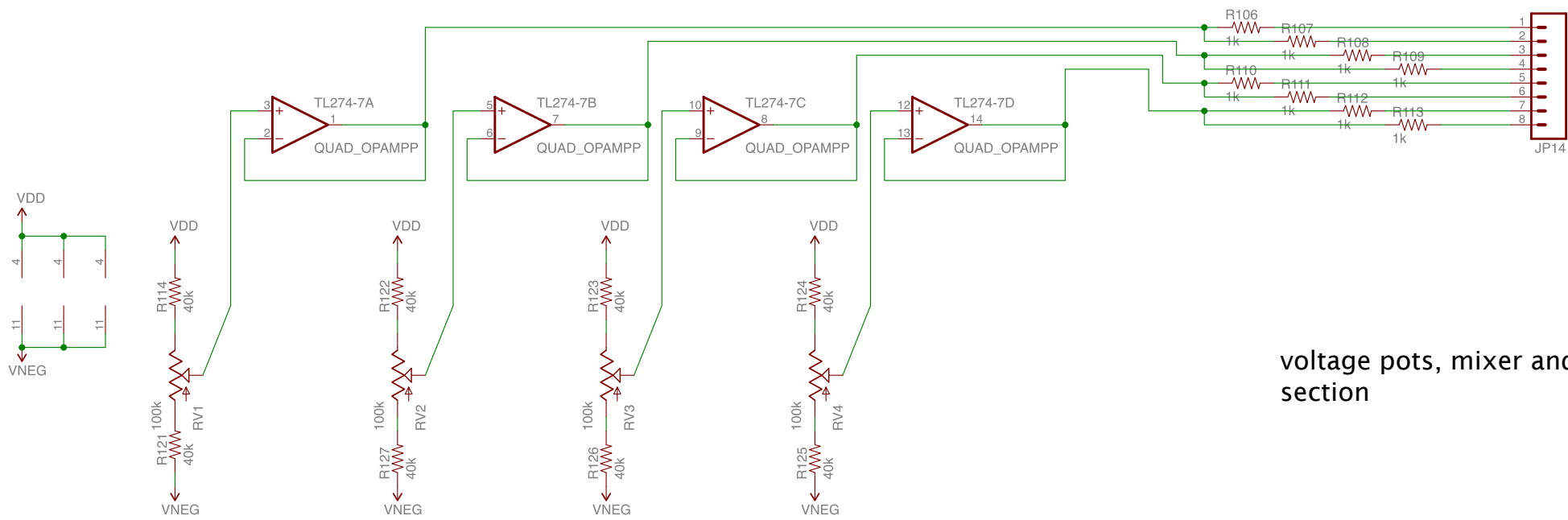

voltage pots, mixer and splitter section

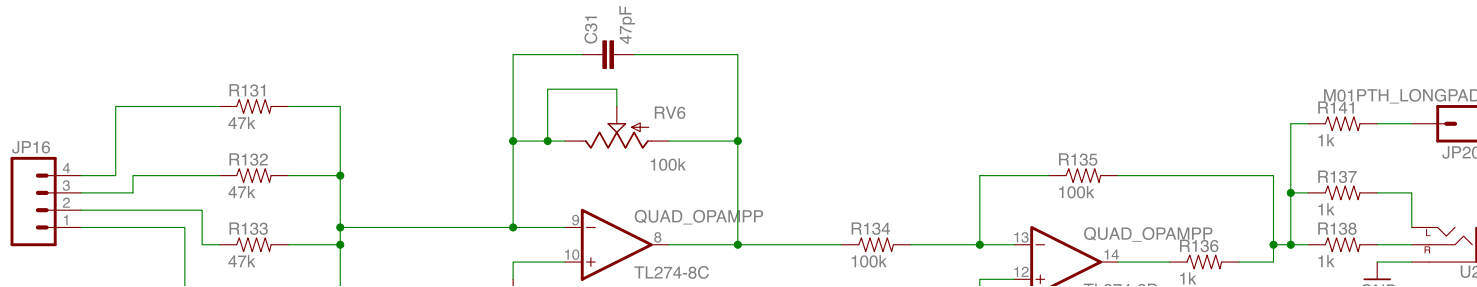
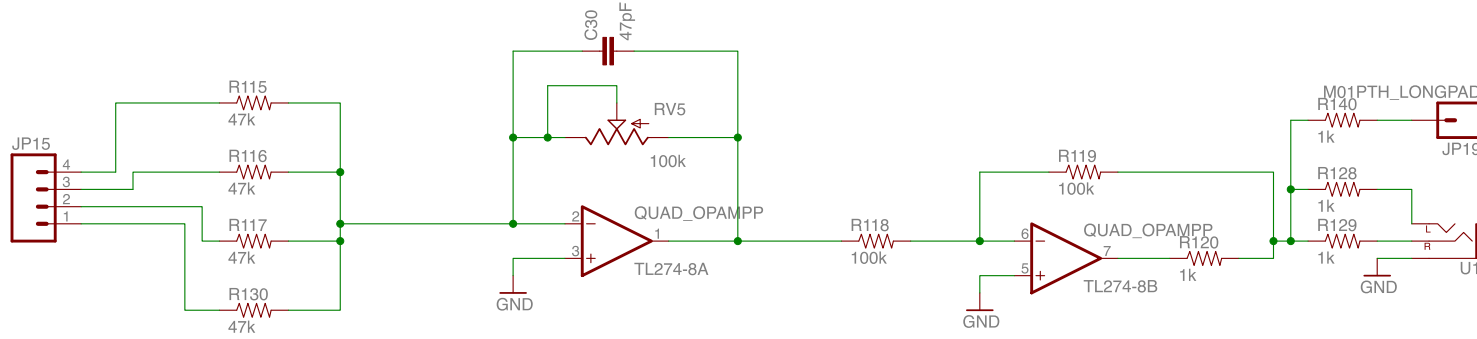



TL274-8D

GND

